

Accumulators

Diaphragm accumulators

Roth
Hydraulics

Technical Information MEAK series

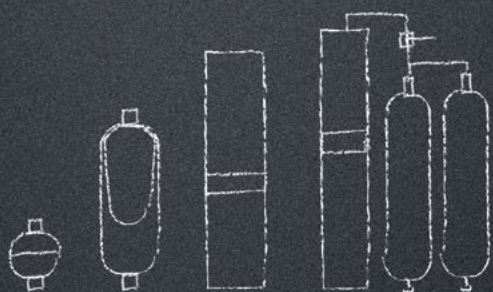

excellent pressure solutions



Contents

Construction and description

General	3
Function	3
Overview of Roth diaphragm accumulators	4
Selection of pressure fluids	4
Series MEAK	5

Acceptance

Acceptance selection table	6
----------------------------	---

Type code MEAK

Series MEAK	7
-------------	---

Series MEAK

Series MEAK NBR 0.07 - 3.5 l	8
Series MEAK Eco 0.32 - 3.5 l	9
Series MEAK NBR 0.5 - 1.4 l	10

Construction and description

■ General



BOLENZ & SCHÄFER has been a leader in the area of accumulator technology for more than 60 years. As a specialist in hydraulic accumulator applications, it is our foremost objective to develop efficient solutions in line with market needs. In the new design of our parent company, Roth Industries – of which Bolenz & Schäfer has been a solid member for more than a quarter of a century – we are proud to continue our activities as Roth Hydraulics.

The **Roth diaphragm accumulator** enhances the product spectrum by a further innovative product. Cost optimised, low maintenance, practically wear resistant, durable, available in versions for special media and applications as well as suitable for use in extreme conditions – these are some of the product's distinguishing features. Roth hydraulic accumulators fulfil all applicable regulations and directives.

Accumulator adapters, safety and shut-off valve blocks along with other accessories can be found in our separate catalogue Accumulator Accessories.



The application fields of the Roth diaphragm accumulator are many and diverse. Amongst other applications, they can be used for:

- > Energy storage
- > Pulsation damping
- > Volume compensation
- > Hydraulic springing
- > Shock absorption
- > Media transfer partition
- > Emergency operation

■ Function

Roth diaphragm accumulators enable the storage and release of hydraulic energy.

As pressurised fluid flows in at the oil connection, the nitrogen becomes compressed. The fluid side and the gas side are separated by a flexible diaphragm. Hydraulic energy is stored.

When the pressure drops in the hydraulic system, the gas expands and drives the fluid out of the diaphragm accumulator back into the hydraulic system. Hydraulic energy is released.

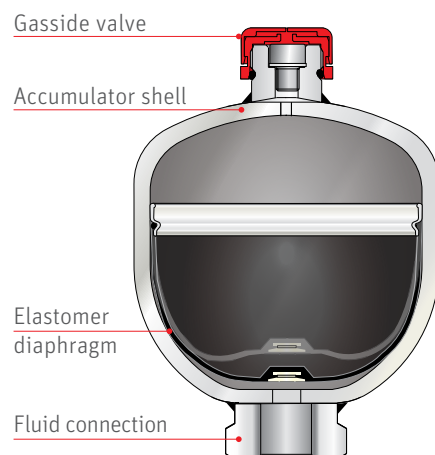

Construction and description

Overview of Roth diaphragm accumulators

Overview of Roth diaphragm accumulators	
Volume	0.07 l ... 3.5 l
Operating pressure	210, 250, 350 bar
Accumulator shell materials	Steel (further materials on request)
Media	Fluid group 2 Pressure Equipment Directive 2014/68/EU (mineral oil based)
Temperature	(according to elastomer) -35 ... +80°C
Volume flow (Q _{max.})	max. 1000 l/min
Installation position	optional, preferably vertical, fluid connection below
Pressure vessel	welded
	coated, UV coating (water based)
Fluid ports	Inside thread G1/2 - G3/4 see table (further fluid port connections on request)
Diaphragm (elastomers)	NBR, ECO
Acceptances	PED 2014/68/EU

Gas pre-charge pressure

The relation between the gas pre-charge pressure and maximum operating pressure (P2) should not be higher than $P0/P2 = 1:6 \dots 8$.

Gas filling

Only nitrogen of Class 4.0 is to be used, never oxygen or compressed air.

Design pressure

The design pressure corresponds to the maximum allowable working pressure (MAWP) and is also the maximum setting pressure of safety equipment against excess pressure (safety valves, burst discs). We recommend operating the accumulators with a maximum pressure of $0.9 \times \text{MAWP}$ to prevent safety equipment from responding.

Accumulator installation

Operating temperature

Standard temperature range: -10°C to +80°C, different temperature ranges, e.g. -40°C to +120°C available upon request.

Condition on delivery

Accumulator shell, welded UV-coated with universal priming in black (similar to RAL 9005). The coating is within the standard C4H. Other colours or other surface coatings are possible on request.

Pressure fluids

Fluids of Group 2 according to the Pressure Equipment Directive 2014/68/EU, or in relation to diaphragm elastomer and temperature range, according to data in the "Pressure fluids" table below. The oil purity class must be at least 19/17/14 (NAS 1638-KJ8) according to ISO 4406.

To prevent damage, the accumulator must be secured according to size and weight. External forces such as vibration or external loading against the diaphragm accumulator must be avoided or taken into consideration when installing.

Operation and maintenance

Please observe the information in the operating instructions for this.

Installation position

The installation position is optional, preferred is a mounting in vertical position with fluid connection below. For filling and testing kits the space requirement above the gas-filling-connection needs a minimum space of 200 mm.

Selection of pressure fluids

	Fluid	Temperature range °C	Elastomer
	... especially for low temperature range*	-32 ... +80	Hydrin C (ECO)
	Fluids based on mineral oil*	-10 ... +80	NBR
	HFA, HFB*	+5 ... +55	NBR
	HFC*	-15 ... +60	NBR
by request	Fluids based on phosphate ester and some synthetic fluids*	-15 ... +120	Butyl (IIR)
	Fluids based on phosphate ester*	-40 ... +120	Ethylene propylene diene (EPDM)
	Hardly flammable and/or synthetic fluids*	-20 ... +140	Viton (FKM)

*Fluid selections for low temperature ranges as well as for temperature applications below -20°C or above +80°C require consultation.

Construction and description

■ Series MEAK

Item	Designation	Material
1	Accumulator shell	Steel
2	Diaphragm	Elastomer, NBR (standard)
3	Gas-filling connection	Steel
4	Clamp ring	Steel
5	Diaphragm plate	Plastic
6	Fluid connection	Steel
7	Protection cap	Plastic

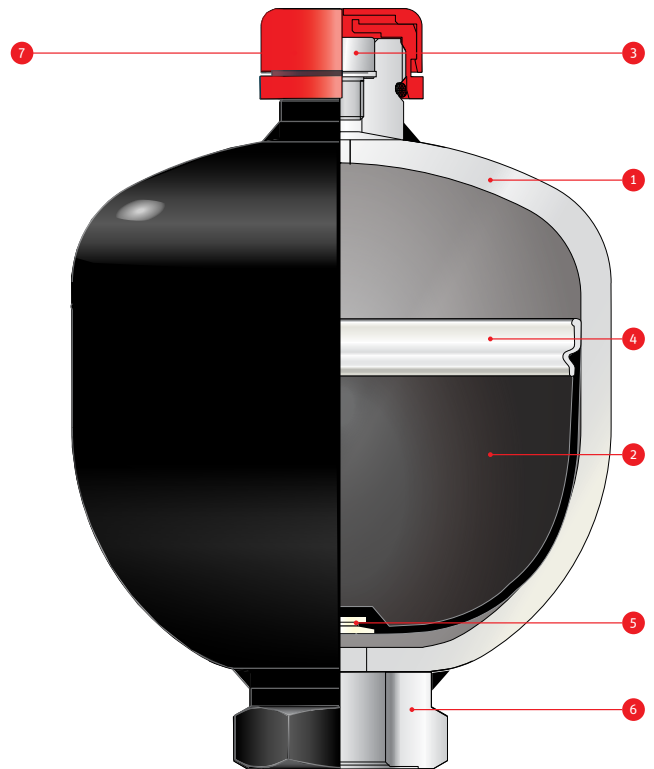

Acceptance

■ Acceptance

Roth hydraulic accumulators are manufactured and approved for the European market in accordance with the "Pressure Equipment Directive".

A conformity assessment procedure according to Pressure Equipment Directive 2014/68/EU has to be carried out for the accumulator systems. Accumulators with a volume > 1 litre bear a CE mark. Accumulators with a volume < 1 litre are designed and manufactured according to article 3 paragraph 3 and do not require a CE mark.

The Pressure Equipment Directive is also accepted by many other countries besides the EU member states. Only some additional approval documentation may sometimes be required. Countries such as Russia, Ukraine or China also require an approval, which Roth Hydraulics has.

Pressure vessel shipments to the USA, on the other hand, must correspond to the American regulations, the ASME Code. Roth Hydraulics has been approved since 1981 according to ASME Code Section VIII Division 1 and therefore has the longest experience with these regulations in Germany as a hydraulic accumulator

manufacturer. Vessels with ASME acceptance are marked with the so-called "U Stamp" and supplied with a data report as acceptance documentation.

However, the scope of the ASME Code only covers pressure vessels and accumulators with an internal diameter greater than 6 inches. The CE series can therefore be used for accumulator diameters less than 6 inches. All Roth diaphragm accumulators conform with this regulation. Vessels according to the ASME Code are also accepted in Canada. In Canada, an additional approval (Canadian Registration Number, CRN) is required for the relevant province to which shipment is destined. The province or installation site must be indicated along with the order. ASME acceptance is often required in the "offshore" field or in parts of Asia.

Roth Hydraulics has all important product and company approvals worldwide. The following tables contain a selection of the most common acceptance variants. If your planned installation country or the required acceptance is not listed, please indicate this in plain text along with the enquiry.

■ Acceptance selection table

Acceptance variants:

Country code	Countries	Approval regulation	Var. no.
EU	EU member states	Pressure Equipment Directive 2014/68/EU with CE mark	50
BR	Brazil	Pressure Equipment Directive 2014/68/EU + CE mark + NR 13 (Brazil)	515

Type code MEAK

Series MEAK

		Order designation	
Series	ME.. -	...-	...-
	▲	▲	▲
	MEAK TYPE	Oil content [l]	max. operating pressure [bar]
Material/Coating (outside)	...-	C = (Standard) carbon steel X = Stainless steel on request V = (Special coating) carbon steel	
Diaphragm material	...-	1 = NBR 2 = (Hydrin) ECO 3 = (Low temperature) TT-NBR on request 4 = (Butyl) IIR on request 5 = (Viton) FKM on request 6 = (Ethylene propylene diene) EPDM on request	
Oil connection	...-	G = Pipe thread (without adapter) ISO 228 R = Pipe thread (with adapter) ISO 228 S = Special thread (please also indicate in plain text) A = Outside thread M33 x 1.5	Please indicate the required thread size / connection nominal width along with this selection.
Acceptance	...-	50 = Pressure Equipment Directive 2014/68/EU 515 = Pressure Equipment Directive 2014/68/EU + NR13	
PO pre-charge pressure	...	0 = (Standard) pre-charge pressure [bar] 0 ... = Filling according to customer request [bar]	

Example: MEAK 2.8 - 250 - C - 1 - G+A - 50 - 100

Product for the example order designation is:

Type:	MEAK
Oil content:	2.8 litres
Pressure:	250 bar
Material:	Carbon steel
Diaphragm:	NBR
Oil connection:	Inside thread: G 3/4 Outside thread: M33 x 1.5
Acceptance:	Pressure Equipment Directive
Pre-charge pressure as required by customer	100 bar

Note: The use of the type code generally ensures our ability to supply.

Diverse diaphragm accumulators with order numbers are listed on the following pages. These are only valid for the types described there. Please observe the corresponding specification!

Series MEAK (NBR)

Series MEAK NBR 0.07 - 3.5 l

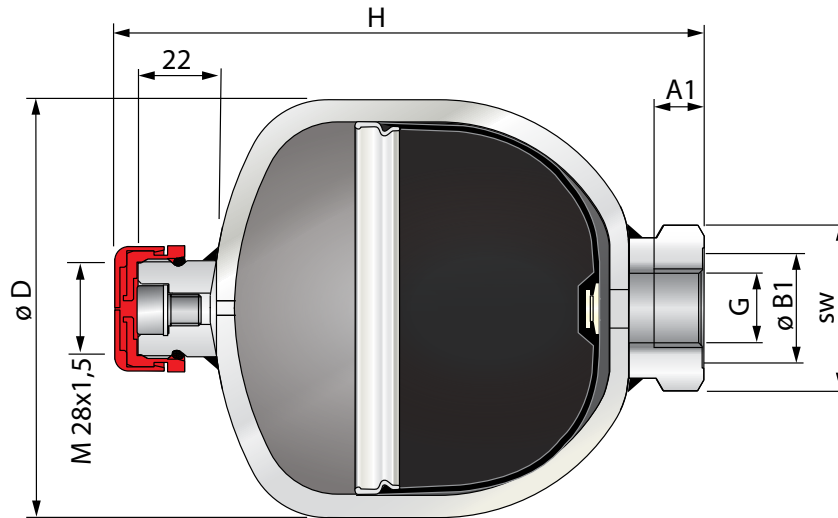

Gas volume		Design pressure		Type / Order number	Note	Temperature range	Weight [kg]	Pressure ratio		Dimensions [mm]					
[l]	[gal]	[bar]	[psi]					Pmax PO	pmax - pmin	G	ø D	A1	B1	H	sw
0.07	0.02	250	3500	MEAK 0.07-250 4204021672	only for MEAK... - C - I - G - 50	-10... +80°C	0.8	≤8:1	175	G ½	64	14	29	118	32
0.16	0.04	250	3500	MEAK 0.16-250 4204021673			1.0	≤6:1	175	G ½	75	14	29	127	32
0.32	0.08	210	3000	MEAK 0.32-210 4204021674			1.5	≤8:1	140	G ½	92.5	14	29	141	32
0.5	0.13	250	3500	MEAK 0.5-250 4204021676			2.0	≤8:1	175	G ½	107	14	34	159	41
0.75	0.2	210	3000	MEAK 0.75-210 4204021677			2.7	≤8:1	155	G ½	121.5	14	34	173	41
0.75	0.2	350	5000	MEAK 0.75-350 4204021679			3.9	≤8:1	150	G ½	128.5	14	34	180	41
1.0	0.26	210	3000	MEAK 1.0-210 4204021680			3.5	≤8:1	140	G ½	136	14	34	187	41
1.0	0.26	350	5000	MEAK 1.0-350 4204021683			4.7	≤4:1	155	G ½	128.5	14	34	206	41
1.4	0.37	250	3500	MEAK 1.4-250 4204021684			5.6	≤8:1	120	G ½	152	14	34	202	41
1.4	0.37	350	5000	MEAK 1.4-350 4204021686			6.8	≤8:1	150	G ½	156	14	33	201	41
2.0	0.53	250	3500	MEAK 2.0-250 4204021688			8.5	≤6:1	140	G ¾	156	14	33	255	41
2.0	0.53	350	5000	MEAK 2.0-350 4204021690			8.5	≤6:1	150	G ¾	156	14	33	254	41
2.8	0.74	250	3500	MEAK 2.8-250 4204021692			8.5	≤6:1	140	G ¾	168	16	33	264	41
2.8	0.74	350	5000	MEAK 2.8-350 4204021694			13.0	≤6:1	200	G ¾	180	16	34	267	55
3.5	0.93	250	3500	MEAK 3.5-250 4204024297			10.2	≤4:1	100	G ¾	169	16	33	315	41
3.5	0.93	350	5000	MEAK 3.5-350 4204024298			15.9	≤6:1	200	G ¾	180	16	34	307	55

Note: The dimensions may vary slightly depending on the materials used and/or applied acceptances. In the event of an order, you will receive a binding drawing for approval for non-standard products.

Series MEAK (Eco)

Series MEAK Eco 0.32 - 3.5 l

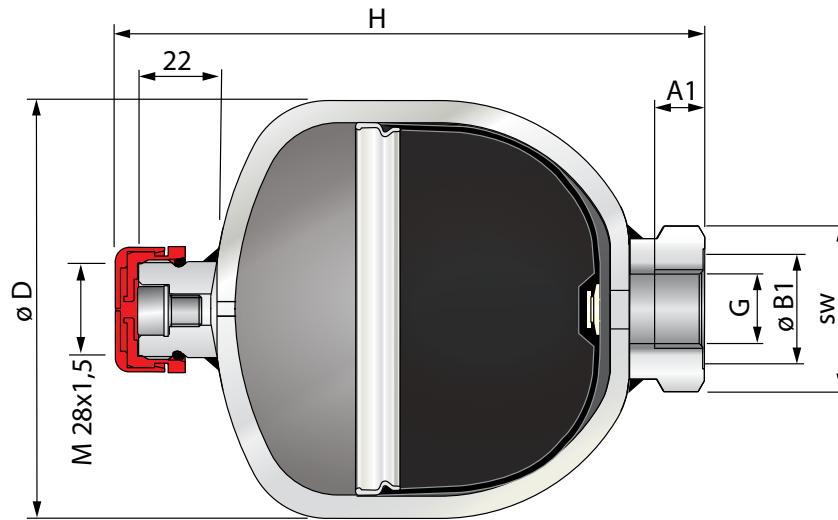

Gas volume		Design pressure		Type / Order number	Note	Temperature range	Weight	Pressure ratio		Dimensions					
[l]	[gal]	[bar]	[psi]					Pmax PO	pmax - pmin	G	ø D	A1	B1	H	sw
0.32	0.08	210	3000	MEAK 0.32-210 4204021675	only for MEAK... - ... - C - 2 - G - 50	-35...+80°C	1.4	≤8:1	140	G ½	92.5	14	29	141	32
0.75	0.2	210	3000	MEAK 0.75-210 4204021678			2.7	≤8:1	155	G ½	121.5	14	34	174	41
0.75	0.2	350	5000	MEAK 0.75-350 4204023761			4.6	≤8:1	150	G ½	128.5	14	34	180	41
1.0	0.26	210	3000	MEAK 1.0-210 4204024312			3.5	≤8:1	140	G ½	136	14	34	187	41
1.4	0.37	250	3500	MEAK 1.4-250 4204021685			5.6	≤8:1	120	G ½	152	14	34	202	41
1.4	0.37	350	5000	MEAK 1.4-350 4204021687			6.8	≤8:1	155	G ½	156	14	33	201	41
2.0	0.53	250	3500	MEAK 2.0-250 4204021689			8.5	≤6:1	140	G ¾	156	14	33	255	41
2.0	0.53	350	5000	MEAK 2.0-350 4204021691			8.5	≤6:1	155	G ¾	156	14	33	255	41
2.8	0.74	250	3500	MEAK 2.8-250 4204021693			8.5	≤6:1	140	G ¾	168	16	33	270	41
2.8	0.74	350	5000	MEAK 2.8-350 4204021695			13.0	≤6:1	200	G ¾	180	16	34	267	55
3.5	0.93	250	3500	MEAK 3.5-250 4204024299			10.2	≤4:1	100	G ¾	168	16	33	315	41
3.5	0.93	350	5000	MEAK 3.5-350 4204024300			15.9	≤6:1	200	G ¾	180	16	34	307	55

Note: The dimensions may vary slightly depending on the materials used and/or applied acceptances. In the event of an order, you will receive a binding drawing for approval for non-standard products.

Series MEAK (NBR)

Series MEAK NBR 0.5 - 1.4 l

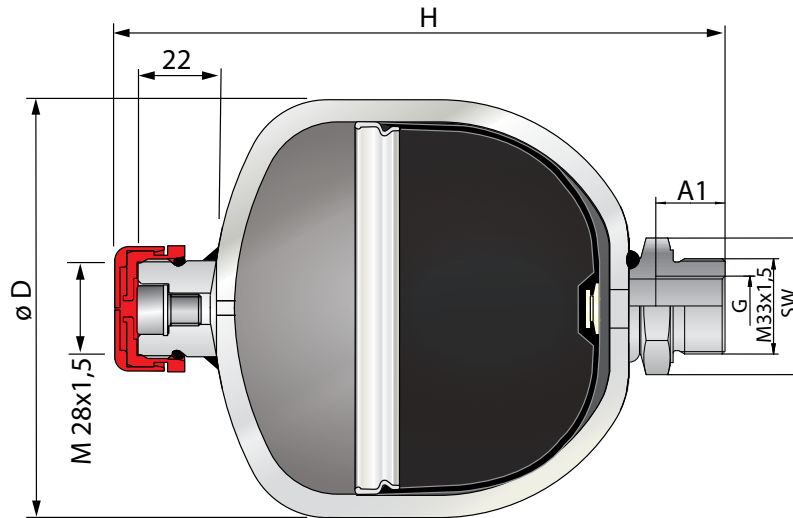

Gas volume		Design pressure		Type / Order number	Note	Temperature range	Weight [kg]	Pressure ratio		Dimensions [mm]				
[l]	[gal]	[bar]	[psi]					Pmax PO	pmax - pmin	G	ø D	A1	H	sw
0.5	0.13	250	3500	MEAK 0.5-250 4204024921	only for MEAK...- ... - C - 1 - G+A - 50	-10... +80°C	2.8	≤8:1	155	G ½	107	18	170	41
0.75	0.2	210	3000	MEAK 0.75-210 4204025457			2.7	≤8:1	140	G ½	121	18	185	41
1.0	0.26	210	3000	MEAK 1.0-210 4204024066			3.5	≤8:1	140	G ½	136.5	24	198	41
1.4	0.37	250	3500	MEAK 1.4-250 4204025475			5.5	≤8:1	120	G ½	152	24	213	41
1.4	0.37	350	5000	MEAK 1.4-350 4204027228			6.6	≤8.1	150	G ½	156	24	212	41

Other versions on request!



Note: The dimensions may vary slightly depending on the materials used and/or applied acceptances. In the event of an order, you will receive a binding drawing for approval for non-standard products.

Our strengths Your benefits

Innovative

- > Own product development
- > In-house technology centre for all relevant tests and inspections including: Burst and swell test bench, endurance test rig, cold chamber, salt spray test
- > Close collaboration with universities and institutes
- > Tested and proven design and simulation program for all types of hydraulic accumulator

Global

- > Worldwide production, assembly and service sites
- > Certified according to DIN EN ISO 9001:2015, DIN EN ISO 14001
- > Proximity to customers thanks to own representatives and extensive dealer network worldwide
- > International production approvals, including ASME U Stamp, Russian Customs Union, Korea KGS

Complete product portfolio

- > Extensive range of diaphragm, bladder and piston accumulators
- > Complete and tested accessories range, including for professional installation and for (accumulator) safety
- > Accumulator measuring and monitoring systems, mechanical or non-contact
- > Customised special solutions

A large, stylized version of the Roth Hydraulics logo, with "Roth" in a bold, white, sans-serif font and "Hydraulics" in a smaller, white, sans-serif font below it, all set against a dark background. A hand is visible at the bottom left, appearing to hold up the logo.



Roth Hydraulics

Accumulators

- > Diaphragm accumulators
- > Bladder accumulators
- > Piston accumulators

Accumulator systems

- > Accumulator units
- > Monitoring systems
- > System accessories
- > Pressure vessels

Special solutions

- > Spring accumulators
- > Damper systems
- > Rail hydraulics
- > Special accumulators

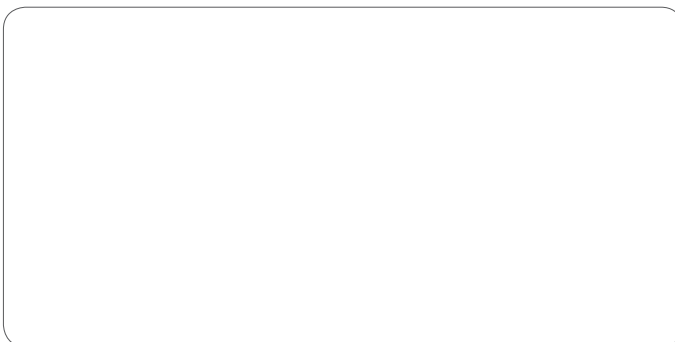

Roth
Hydraulics



ROTH Hydraulics GmbH
(formerly Bolenz & Schäfer GmbH)
Lahnstraße 34
D-35216 Biedenkopf-Eckelshausen
Germany
Phone: +49 (0) 64 61/9 33-0
Fax: +49 (0) 64 61/9 33-161
Email: service@roth-hydraulics.de
www.roth-hydraulics.de



ROTH Hydraulics (Taicang) Co., Ltd.
(formerly BSD Hydraulic Technology (Taicang) Co., Ltd.)
Building 14 A, No. 111,
Dongting North Road, Taicang City,
Jiangsu Province 215400, P.R. China
Phone: +86 (0) 512/53 20 88 36
Fax: +86 (0) 512/53 20 88 39
Email: service@roth-hydraulics.com.cn
www.roth-hydraulics.com.cn



ROTH Hydraulics NA Inc.
One General Motors Drive,
PO Box 245, Syracuse
New York 13211
USA
Phone: +1 (0) 315/4 75 01 00
Fax: +1 (0) 315/4 75 02 00
Email: service@roth-hydraulics.com
www.roth-hydraulics.com